



REMOTE GALLERY

Introductory Package

About Remote Gallery

Remote Gallery is Akin's dedicated exhibition and programming space located at 568B Richmond Street West. Remote Gallery provides opportunities for artists and members of the public to rent financially-accessible space for various types of programming.

Our versatile venue is open for single or multi-day rentals, accommodating workshops, presentations, meetings, community events, exhibitions, performances, and various artistic programs.

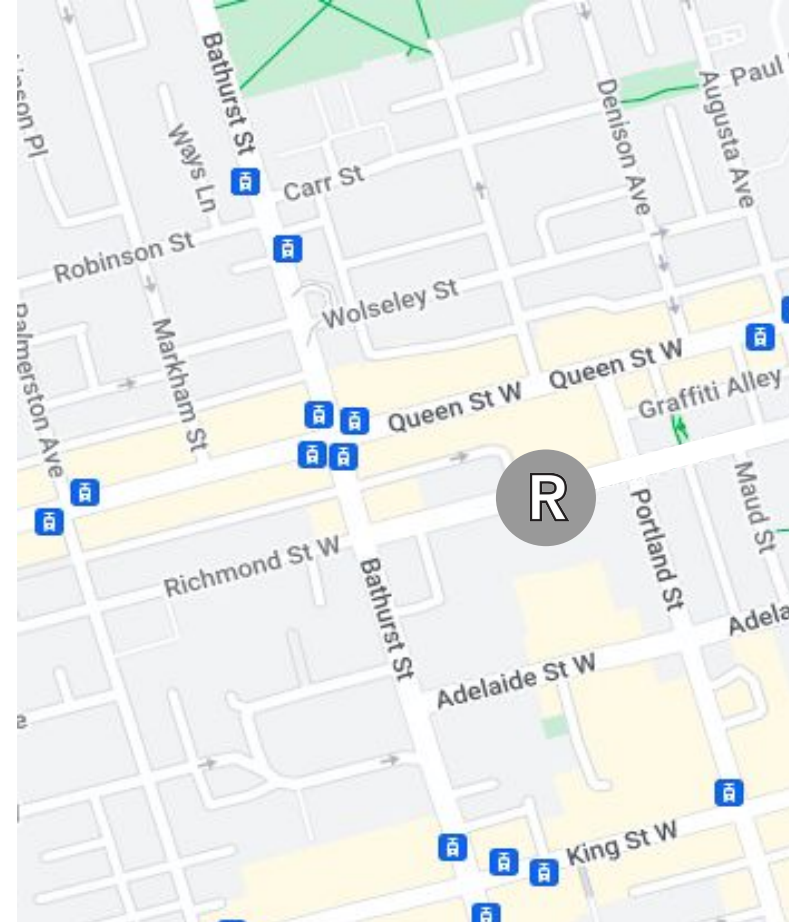

568 Richmond St W, Toronto, ON M5V 1Y9

Remote Gallery Features

- 300 sq ft
- 40 person occupancy
- Wifi, 5 Outlets
- Gallery-quality fluorescent lighting
- Polished concrete floors
- Easy access via transit and on the ground floor
- Automated accessible entrance (For all accessibility details click [here](#))
- InFocus LP600 Projector (Click [here](#) for all specs)
- 2 Plinths: 21" x 18" x 33"(h) and 12" x 20" x 39.5"(h)
- 15 foldable chairs, 6 foldable tables (6') & 1 table (4')



Remote Gallery Floor Plan

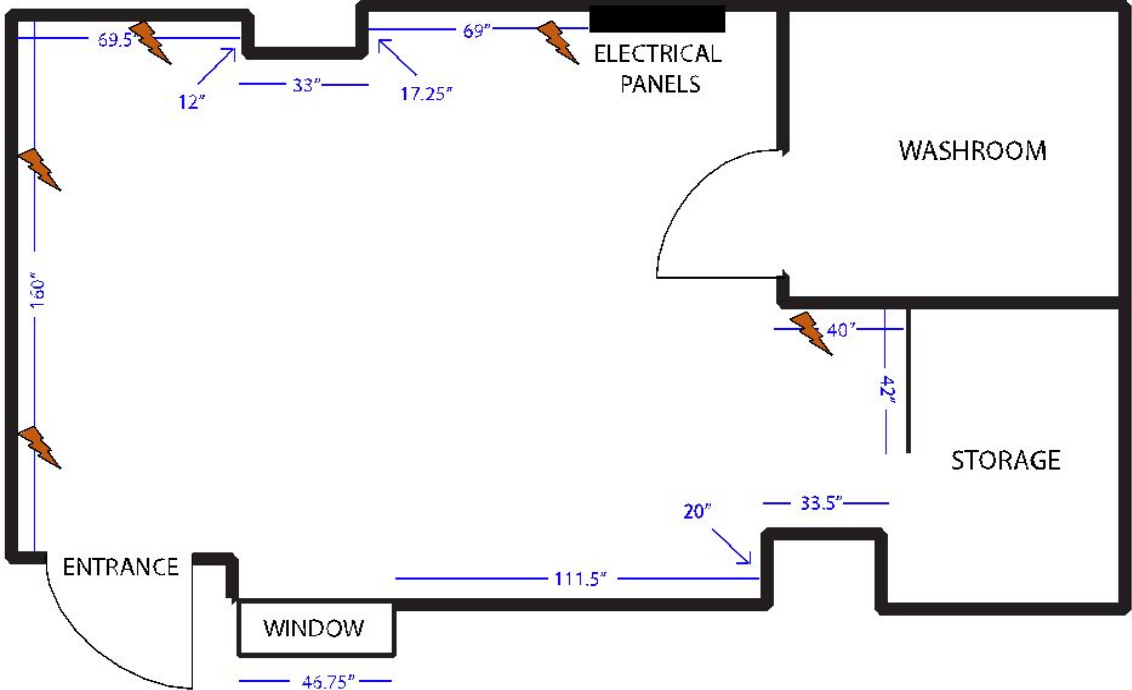

The Gallery Space

Contact gallery@akincollective.com to arrange a gallery tour. Click [here](#) to view a video of the space.

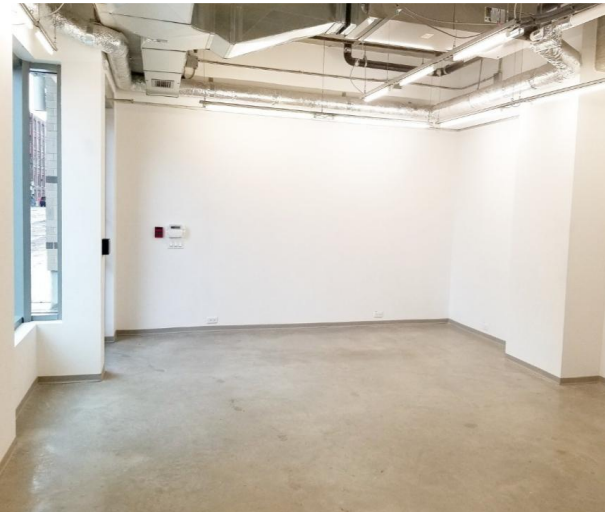
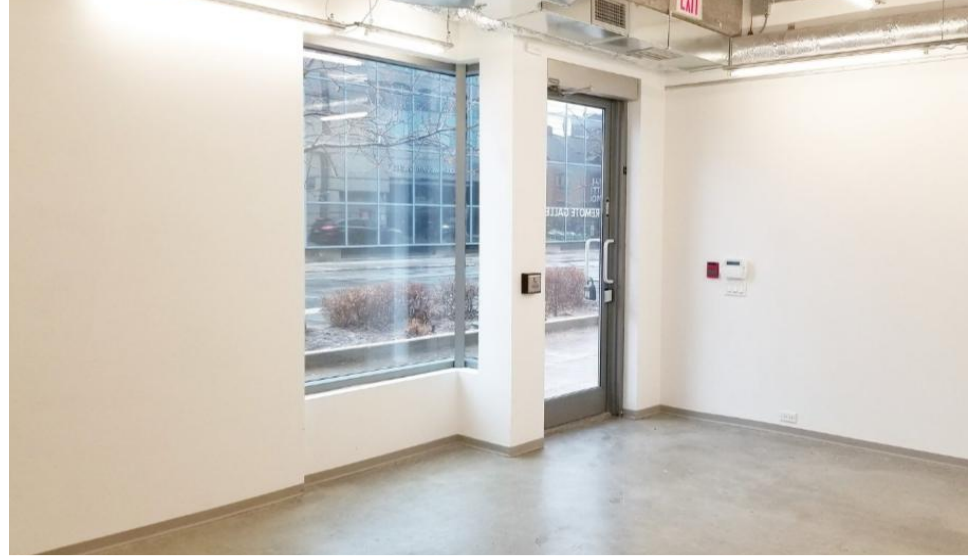

Space Configurations

Displayed here are a range of spatial setups utilized in past workshops and presentations.



Past Exhibitions

Photographs from past exhibitions illustrate the various ways space can be curated.

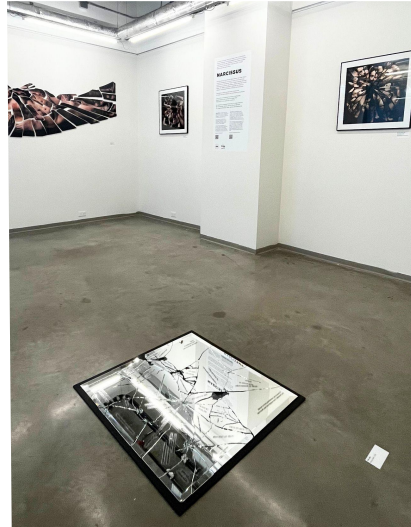

Testimonials

“I can’t thank you enough and Akin for this incredible opportunity. I had a beautiful show. Lots of visitors. The space was lovely”. - *Catherine Tamarro*

“Just wanted to say thanks. I’m really happy with how the show turned out and the space is just great”. - *Stephen Severn*

“Thank you so much for having our show, it has been an honour to have our special show at Remote Gallery. I will recommend the space to others”! - *Mark Krzepis and Rayan Johnston*

"I wanted to say a big big thank you again for helping me make that dream a reality! It was so amazing that Ady Torres-Bliley and I were able to do a show at Remote. It meant the world to us, and we will be talking about it for years". - *Paris Canham*



Questions & Answers 1/3

1: Am I permitted to drill holes in the wall?

Yes, however prior to leaving the space, please ensure to fill the holes with spackling, sand them down, and repaint the affected areas. Necessary tools and supplies for this task can be found in the storage area.

2: Can I use vinyl on the wall and/or window?

Yes. Make sure to use removable vinyl to prevent surface damage when removing them. On the window, the vinyl needs to be applied from outside.

3: Can I hang works from the ceiling?

It depends. We do not have a structure for ceiling hanging. If the work is lightweight (less than 3 kg), you may use small hooks for lightweight items. Approval is needed for anything over 3kg.

4: Do you have speakers in the gallery?

No, you need to bring your own speakers.

5: Can I serve food and drinks in the gallery?

Yes, however the gallery lacks space for food preparation or heating. For alcohol service, a Toronto [Special Occasion Permit](#) and a Smart Serve-certified individual is required.

6: Who opens and closes the gallery?

These times are your decision. During your show, you're responsible for opening, staying, and securely closing the space.

7: Will Akin promote my show?

Yes. Akin promotes exhibitions on Remote Gallery's Instagram page close to the opening date. Please

Questions & Answers 2/3

Provide all information at least 1 month before the opening. You must provide:

- Title of the exhibition.
- Image cropped to 1080x1080
- Author/artists names (and Instagram addresses if you want to be tagged).
- A short paragraph presenting the show.
- Days and times open to the audience (weekdays, weekends, and the opening day/night).
- Any other information you consider important.

8: How can I access the gallery and Wi-Fi?

The code for the key box on the front door and the Wi-Fi password will be emailed to you 2 days before your entry. Information about garbage disposal and emergency contacts will also be included in this email.

9: What time can I enter to set up the exhibition and leave the space?

Starting in 2024, entry is set at 12 pm on your first day. If you require more time for setup, inform us, and we'll try make arrangements.

10: Are the assembly and disassembly days part of my renting days?

Yes, please take this into account when booking.

11: Can I set up/continue my exhibition throughout the night?

Yes. We suggest working/exhibiting in the space until 11 pm. If more time is needed, please perform quiet tasks as we follow [Toronto's Noise Bylaw](#).

Questions & Answers 3/3

12: Can I smoke or vape in the space?

No, smoking or vaping is not permitted in the space.

13: Are pets allowed in the gallery?

There is no restriction, but remember that you're responsible for returning the space in the same condition as when you entered it. During your show, you decide what's best regarding pets.

14: Do you provide gallery attendants?

No, artists are responsible for providing gallery attendants for their exhibitions, and planning any associated events and receptions. Additional staffing and promotion available for an additional cost.

15: Can I use a small part of my credit to pay gallery attendants? (This only applies to Space Award Winners)

Yes, you can use a portion of your credit to cover Gallery sitting costs, as long as they provide an invoice to Akin.

16: Can I sell my works in the exhibition? Does Remote Gallery/Akin take a fee?

Yes, you are allowed to sell your artworks during the exhibition. Akin does not take any of your sales.

2024 Rental Information for Artists

Rental Fee:

\$206/day,
\$1083/week (7 days)

Maintenance Fee:

\$30

Attendant Rental:

\$20/hour

We will also require a damage deposit which will be returned to you once the exhibition/event is complete and it is verified there is no undue damage

This rental pricing does not include any additional services, meaning that the artist will take care of main promotional materials, equipment/installation costs, opening reception costs, gallery sitting, etc.

We request that you send us the following information to gallery@akincollective.com

- Suggested dates for your show/event
- A summary of your proposed exhibition/event
- A bio and CV (if applicable)
- Images of the work, or similar work if it is still a work in progress (if applicable)

2024 Rental Information for Akin Members & Space Award Winners

Rental fee:

\$165/day

\$866/week (7 days)

\$2787/month

Maintenance fee:

\$30

Attendant Rental:

\$20/hour

We will also require a damage deposit which will be returned to you once the exhibition/event is complete and it is verified there is no undue damage.

This rental pricing does not include any additional services, meaning that the artist will take care of main promotional materials, equipment/installation costs, opening reception costs, gallery sitting, etc. Some of these services may be available through Akin for an additional cost, please inquire if you would like more information.

Email with access orientation will arrive 2 days before the entry.

Cancellation must be at least with 1 month in advance.

Process for booking:

- Send suggested dates for your show to gallery@akincollective.com
- We will send you final date confirmation, a contract to be signed along with an invoice to be paid.

*Week rental recommendation:
From Wed (12pm) to Tues (11pm)*

Promotional Information

If you would like us to promote your show on our Instagram please submit image and content one month before the show.

- Title of the exhibition.
- Image cropped to 1080x1080
- Author/artists names (and Instagram addresses if you want to be tagged)
- A short paragraph presenting the show
- Days and times open to the audience (weekdays, weekends, and the opening day/night)
- Any other information you consider important.

Contact

To inquire about Remote Gallery rental please email gallery@akincollective.com.

Please include a brief description of your exhibition or programming idea, the dates you are looking at, and any other pertinent information in your inquiry. We aim to make our space rentals as financially accessible as possible and look forward to hearing your ideas.

www.remote.gallery
@remotegallery



Akin is committed to maintaining an anti-oppressive, queer and trans-positive environment, welcoming Indigenous, equity-deserving, racialized folks, and folks with disabilities. Akin's studio locations are located on the territory of the Anishinaabe, Haudenosaunee and traditional territory of the Wendat. You can find out more about Akin at www.akin.art



A huge thank you to the Toronto Arts Council for their collaboration on this space, without whom this would not have been possible. Special thanks also to our friends and collaborators Neighbourhood Arts Network and Toronto Employment and Social Services' Art Connections program.